

QUICK START GUIDE

ski~mojo

Please read, understand and accept the SAFETY PRECAUTIONS & DISCLAIMER in the USER GUIDE before any use of the Ski-Mojo.

Veillez lire, comprendre et accepter les AVERTISSEMENTS & SECURITE dans le MANUEL UTILISATEUR avant toute utilisation du Ski-Mojo.

Bitte lesen, verstehen und akzeptieren Sie die SICHERHEITSVORKEHRUNGEN & HAFTUNGS AUSSCHLUSS im Bedienungsanleitung bevor Sie den Ski-Mojo verwenden.

Si prega di leggere, comprendere e accettare le MISURE DI SICUREZZA E AVVERTENZE LEGALI nel MANUALE D'USO prima di utilizzare il Ski-Mojo.

A

LEFT

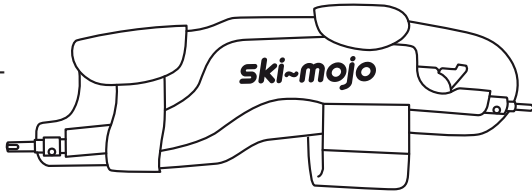

RIGHT



B

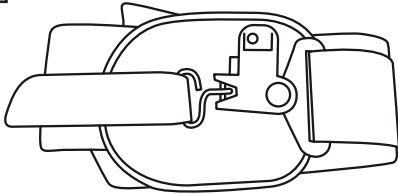

C

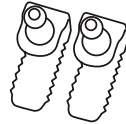

D



E

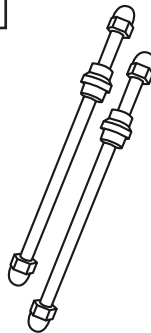

F



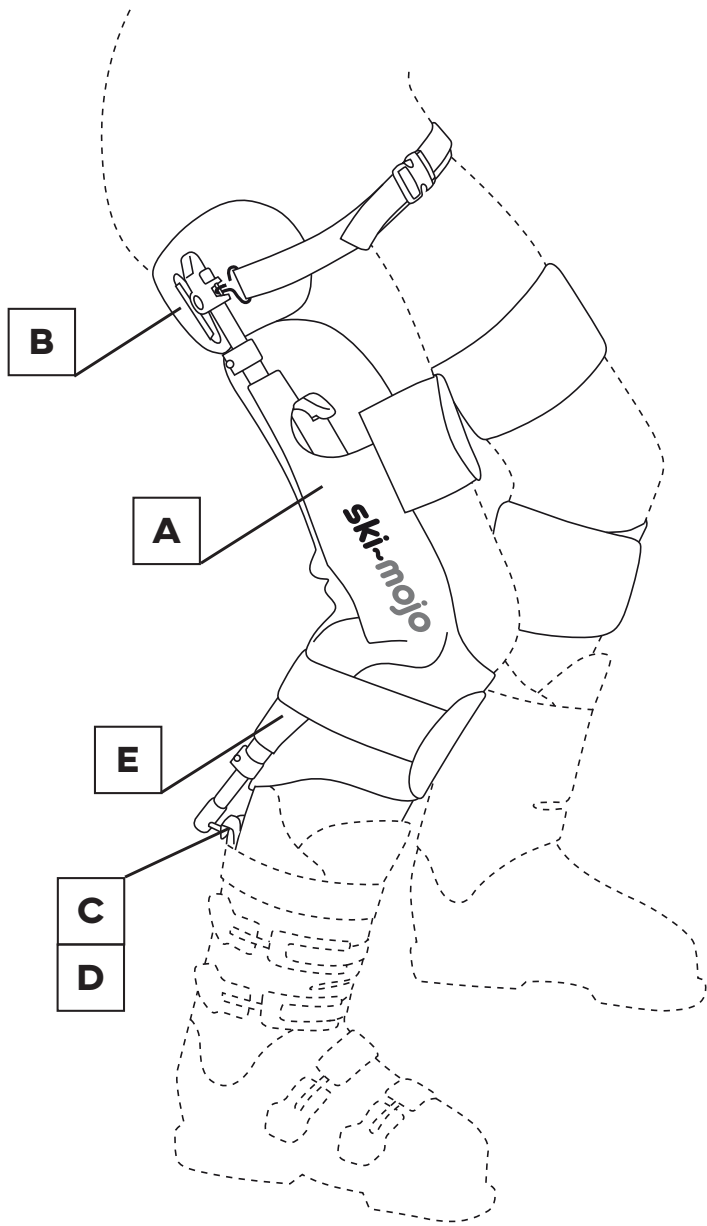

1

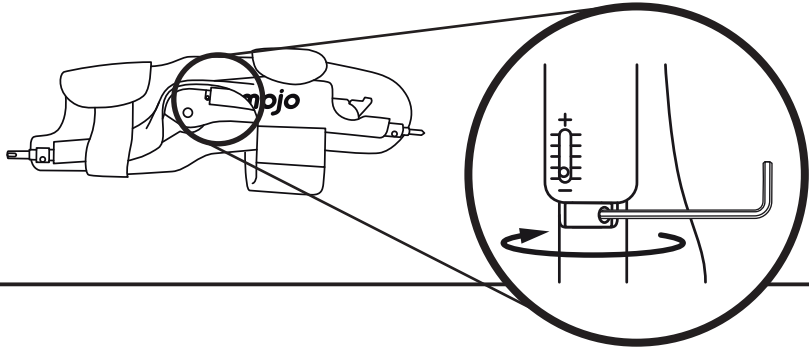
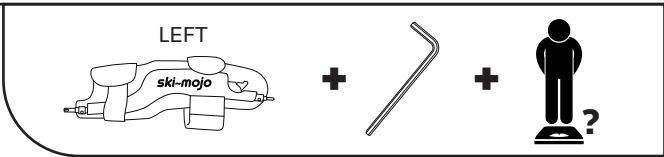

| GOLD | | | |
|------|-----|-----|----|
| | Kg | Lb | ↻ |
| + | 123 | 271 | 24 |
| | 121 | 266 | 23 |
| | 119 | 262 | 22 |
| | 117 | 257 | 21 |
| | 115 | 253 | 20 |
| + | 113 | 249 | 19 |
| | 111 | 244 | 18 |
| | 109 | 240 | 17 |
| | 107 | 235 | 16 |
| | 105 | 231 | 15 |
| + | 103 | 227 | 14 |
| | 101 | 222 | 13 |
| | 99 | 218 | 12 |
| | 97 | 213 | 11 |
| | 95 | 209 | 10 |
| + | 93 | 205 | 9 |
| | 91 | 200 | 8 |
| | 89 | 196 | 7 |
| | 87 | 191 | 6 |
| | 85 | 188 | 5 |
| + | 84 | 185 | 4 |
| | 83 | 182 | 4 |
| | 82 | 180 | 3 |
| | 81 | 178 | 3 |
| | 80 | 177 | 2 |
| + | 79 | 174 | 2 |
| | 77 | 170 | 1 |
| | 76 | 168 | 0 |

| SILVER | | | |
|--------|----|-----|----|
| | Kg | Lb | ↻ |
| + | 87 | 191 | 24 |
| | 85 | 188 | 23 |
| | 84 | 185 | 22 |
| | 83 | 182 | 21 |
| | 82 | 180 | 20 |
| + | 81 | 178 | 19 |
| | 80 | 177 | 19 |
| | 79 | 174 | 18 |
| | 77 | 170 | 17 |
| | 76 | 168 | 16 |
| + | 75 | 165 | 15 |
| | 73 | 162 | 14 |
| | 72 | 159 | 13 |
| | 71 | 156 | 12 |
| | 69 | 153 | 11 |
| + | 68 | 150 | 10 |
| | 67 | 147 | 9 |
| | 65 | 144 | 8 |
| | 64 | 141 | 7 |
| | 63 | 138 | 6 |
| + | 61 | 135 | 5 |
| | 60 | 133 | 4 |
| | 59 | 130 | 3 |
| | 57 | 127 | 2 |
| | 56 | 124 | 1 |
| + | 55 | 121 | 0 |

| BLUE | | | |
|------|----|-----|----|
| | Kg | Lb | ↻ |
| + | 62 | 136 | 24 |
| | 61 | 135 | 23 |
| | 60 | 133 | 22 |
| | 59 | 130 | 21 |
| | 58 | 128 | 20 |
| + | 57 | 127 | 19 |
| | 56 | 124 | 18 |
| | 55 | 121 | 17 |
| | 54 | 118 | 16 |
| | 53 | 117 | 15 |
| + | 52 | 115 | 14 |
| | 51 | 112 | 13 |
| | 50 | 109 | 12 |
| | 49 | 108 | 11 |
| | 48 | 106 | 10 |
| + | 47 | 103 | 9 |
| | 46 | 101 | 8 |
| | 45 | 101 | 7 |
| | 44 | 98 | 6 |
| | 43 | 95 | 5 |
| + | 42 | 92 | 4 |
| | 41 | 89 | 3 |
| | 40 | 88 | 2 |
| | 39 | 86 | 1 |
| | 38 | 83 | 0 |

2

RIGHT



+

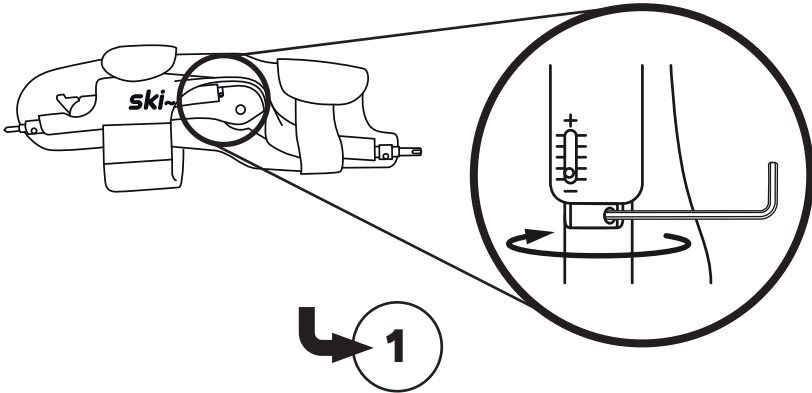

3

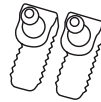

+



+

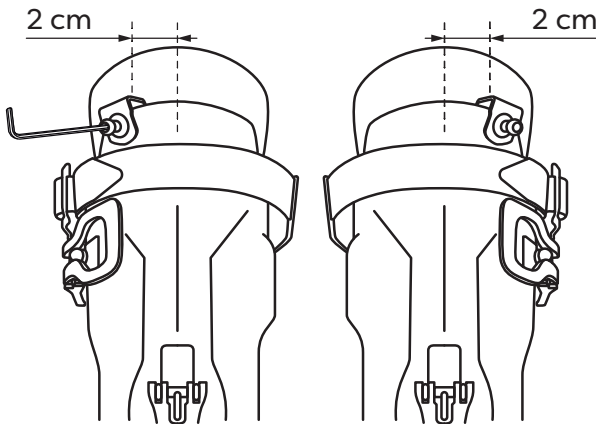

LEFT

RIGHT

4

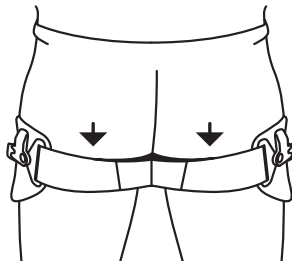
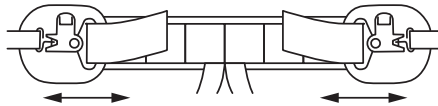
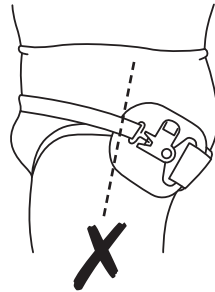
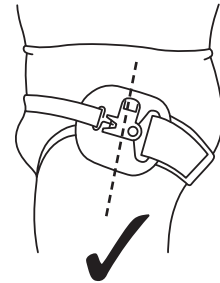
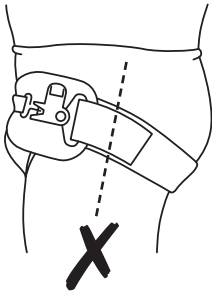
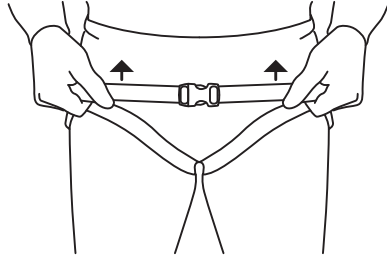
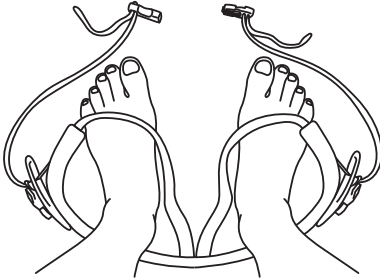
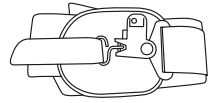

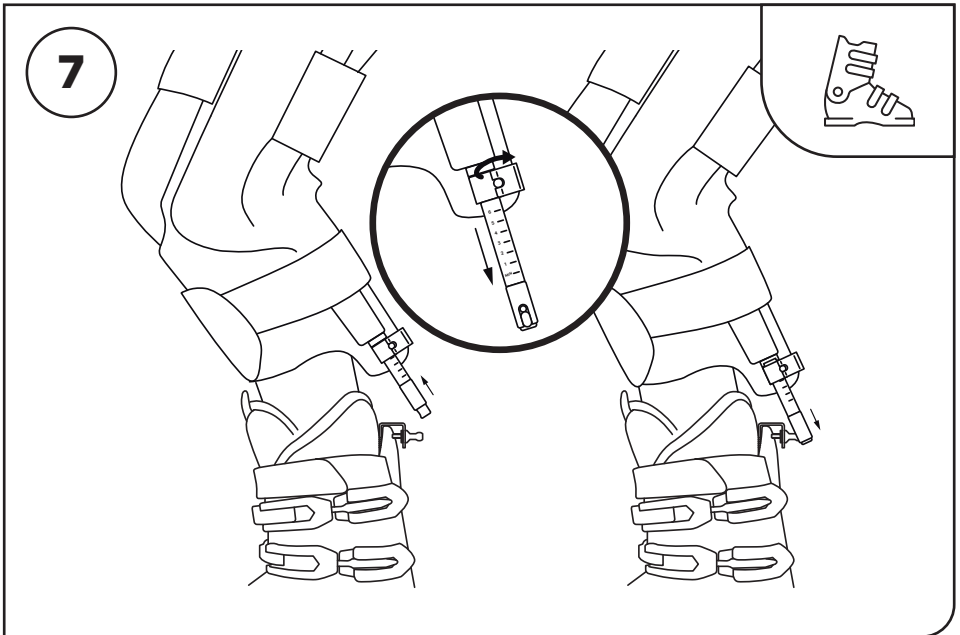
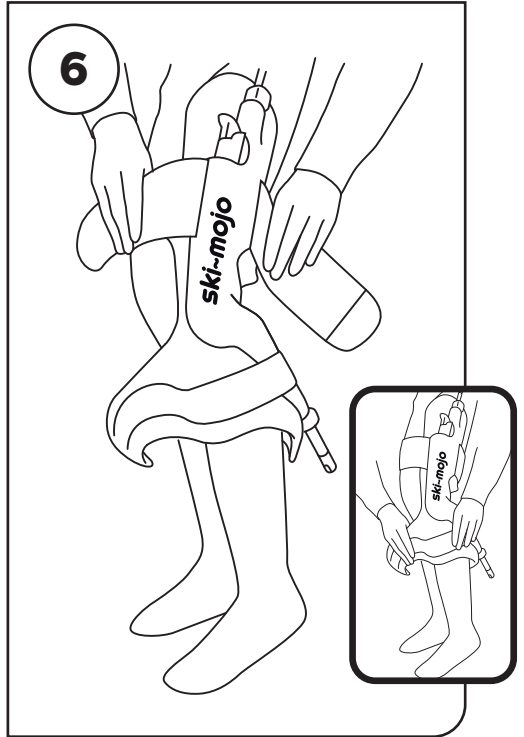
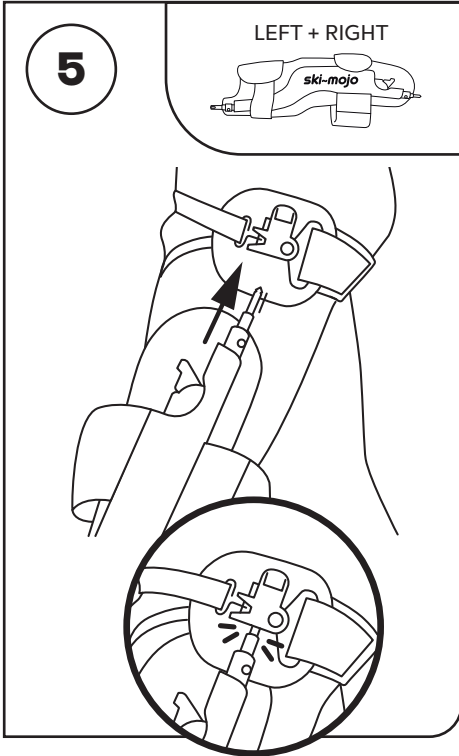

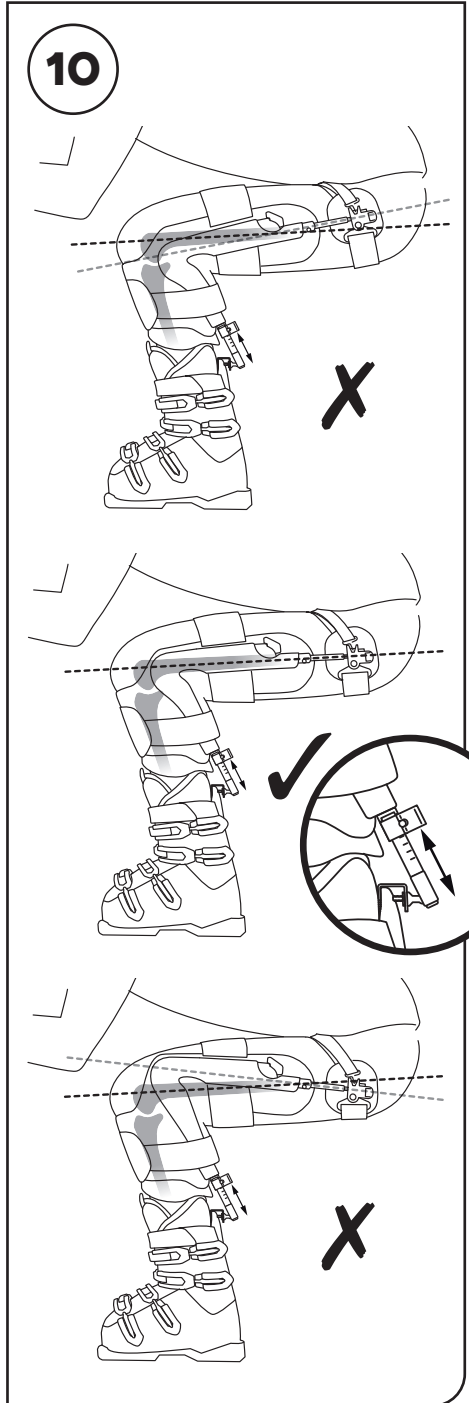
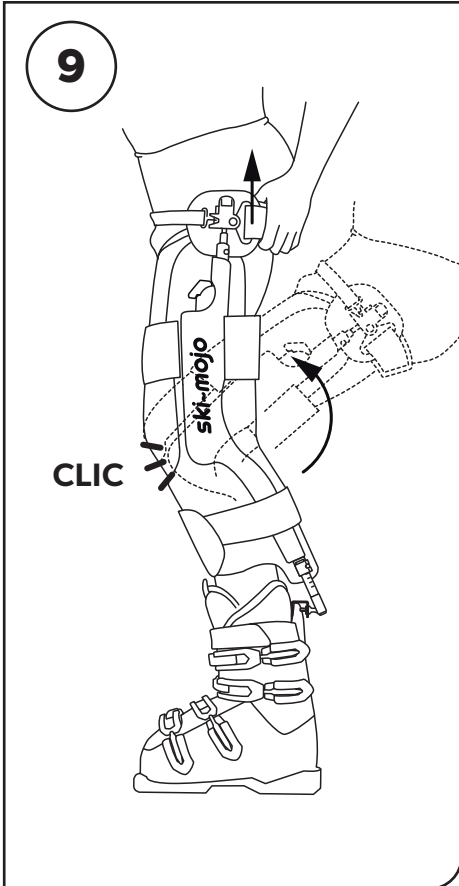
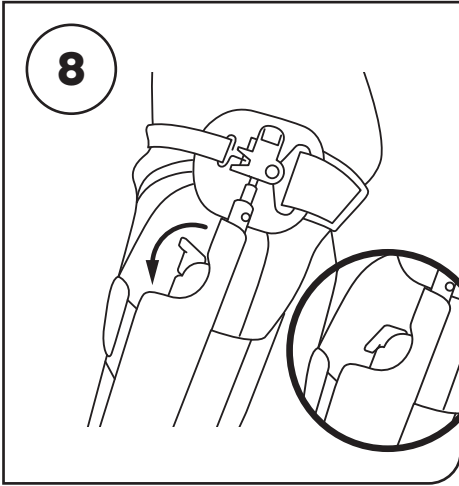

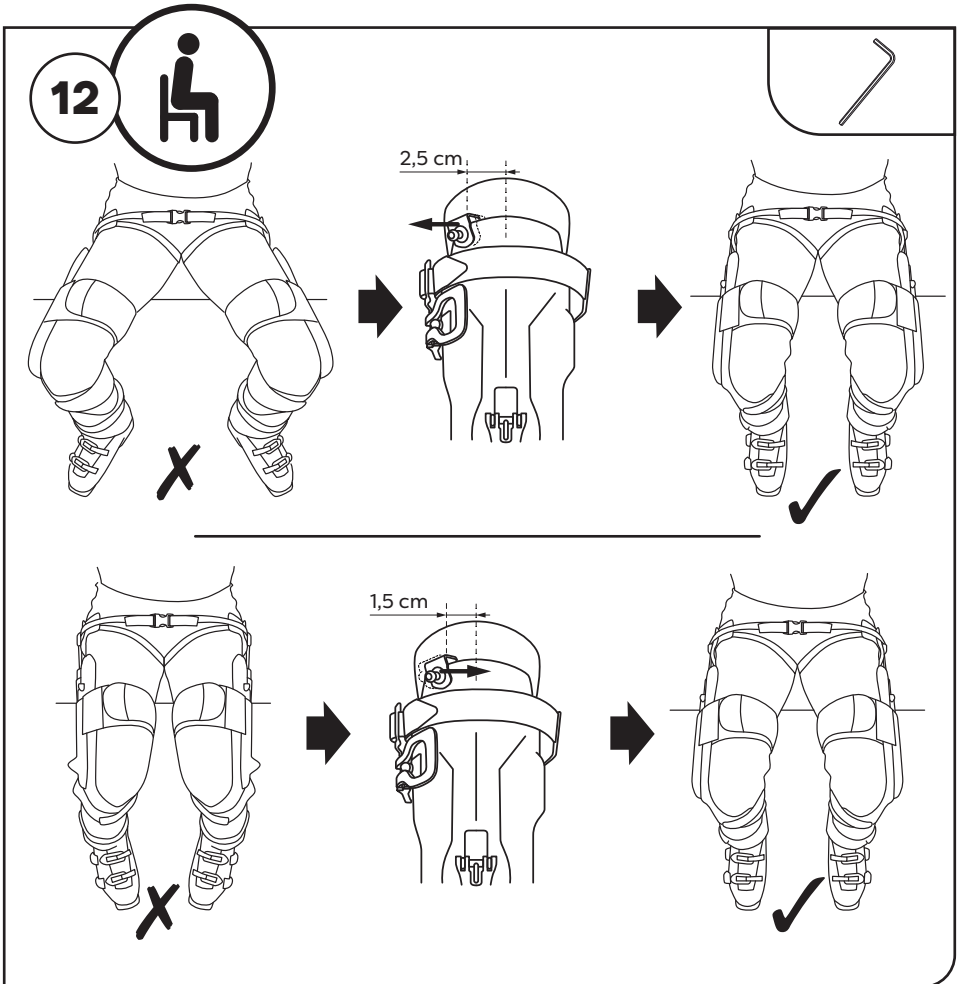
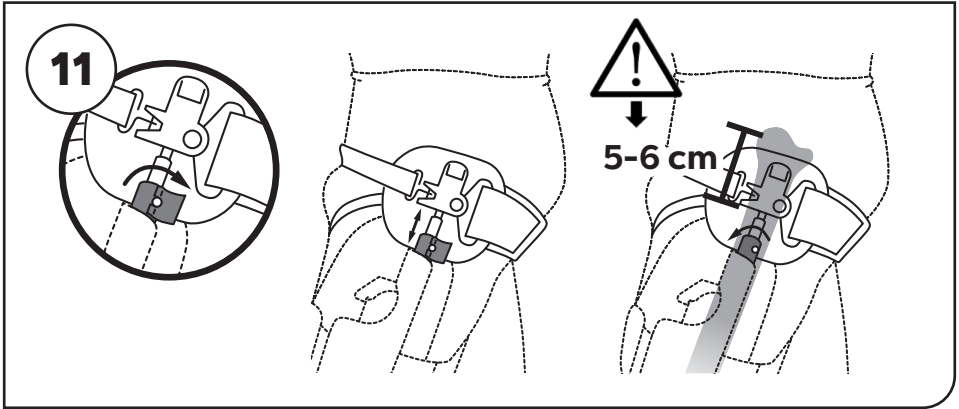

13

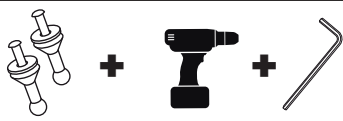
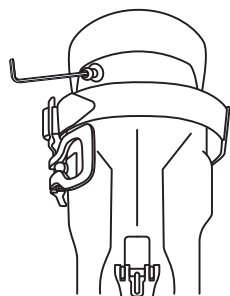
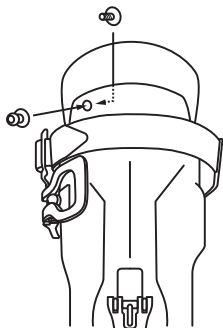
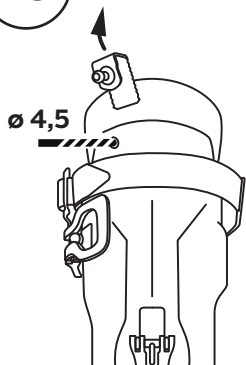

14

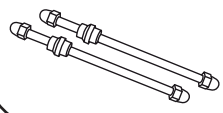
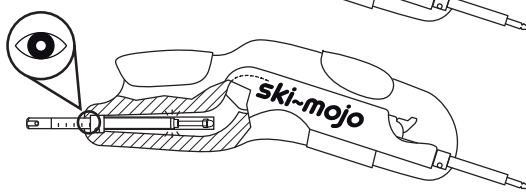
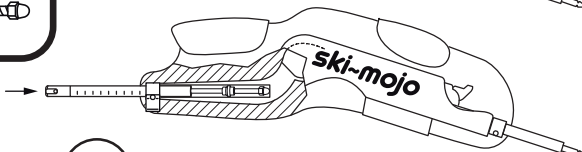
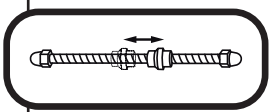
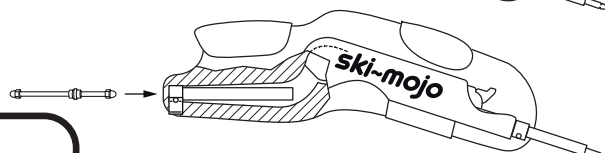
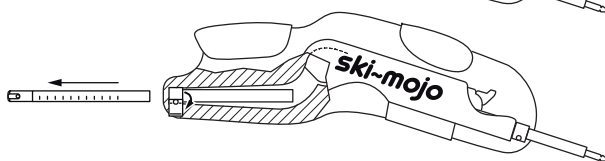
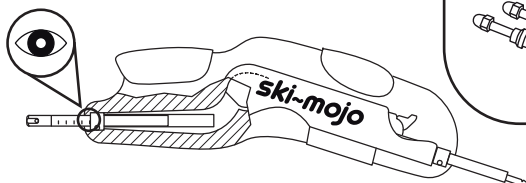

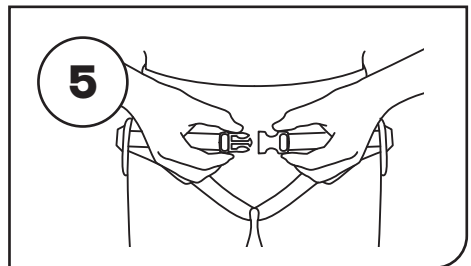
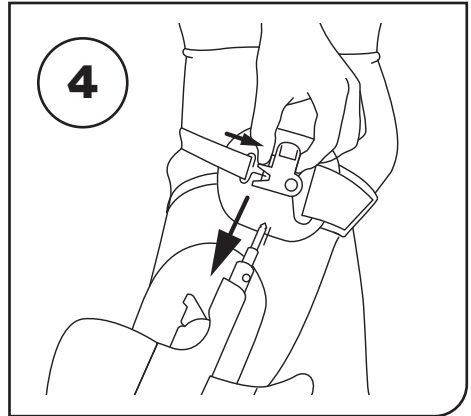
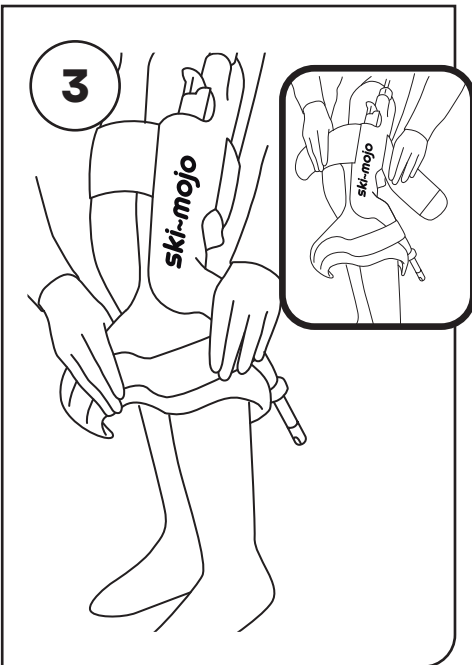
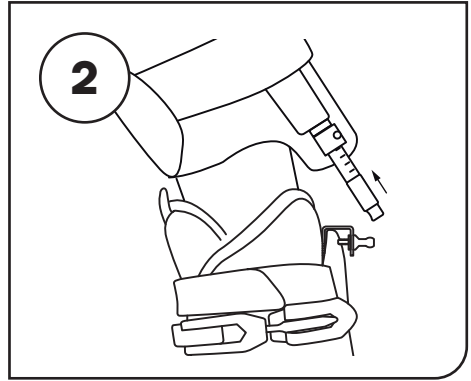
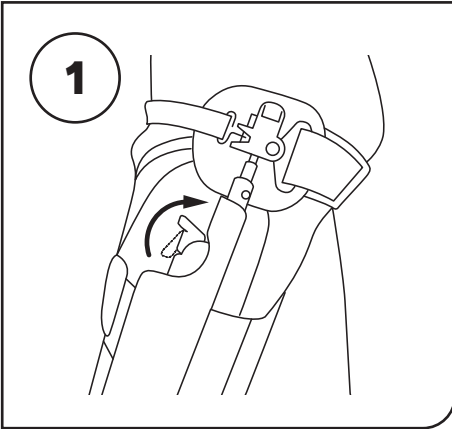



ski~mojo

www.ski-mojo.com/help

